

# SAW Filters

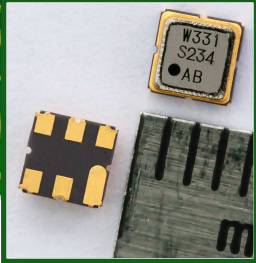

**TEMEXPRESS**

## **TMX W331**

Low Loss Bandpass SAW Filter – REMOTE CONTROL - RF  
*Specification (Rev 5)*

▣ Features .....	P01
▣ Package drawing & Pin out .....	P01
▣ Marking .....	P01
▣ Technical characteristics .....	P02
▣ Measurement circuit .....	P02
▣ Frequency characteristics .....	P03
▣ Maximum ratings .....	P04
▣ Recommended reflow soldering profile .....	P04
▣ Tape Specifications .....	P05
▣ Reel Specifications .....	P05
▣ Reliability tests.....	P06

# TMX W331

## Low Loss SAW Bandpass Filter – REMOTE CONTROL

Specification (Rev 5)

January 16<sup>th</sup>, 2013

### Features

- ❑ RF SAW Filter for wireless applications such as Smart metering, Home appliances and Security systems
- ❑ 869 MHz Center Frequency
- ❑ Ceramic package for Surface Mounted Technology
- ❑ Low Loss (typically 2.5dB) within PassBand Width 868MHz to 870MHz
- ❑ Good rejections specially near the GSM carrier at 912MHz (-60dB)
- ❑ Maximum pulse power : 27dBm
- ❑ Already used with main RF chipsets as Analog Devices, Infineon, Melexis, Semtech and Texas Instruments.

### Package drawing & Pin out

The product is in conformance with the European RoHs Regulation 2002/95.

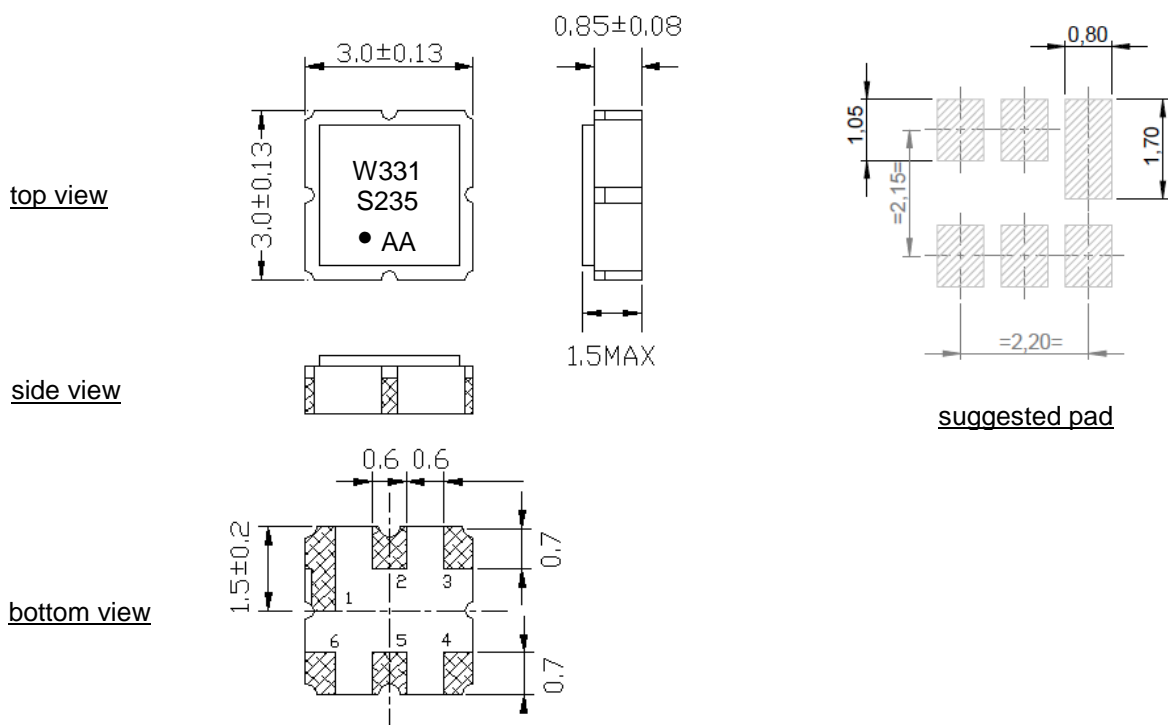

unit : mm

Pin configuration	
2	Input
5	Output
1,3,4,6	Ground

Marking		
Line 1	W331	Temexpress designation
Line 2	S235	S is production Code / 2 is Year 2012 & 35 is Week 35
Line 3	AA	AA" is internal production batch code, it corresponds to the wafer

Marking is made by Laser

# TMX W331

## Low Loss SAW Bandpass Filter – REMOTE CONTROL

Specification (Rev 5)

January 16<sup>th</sup>, 2013

### Technical characteristics

Reference Temperature: +25°C

Electrical Parameters	Unit	Minimum	Typical <sup>(1)</sup>	Maximum
Center Frequency fo	MHz	-	869	-
PassBand Width	MHz	-	868 ~ 870	-
Insertion Loss in 868MHz – 870MHz	dB	-	2.5	3.4
Amplitude Ripple in 868MHz – 870MHz	dB	-	0.3	1.5
<b>Absolute Attenuation</b>				
D.C ~ 300 MHz	dB	45	50	-
300 ~ 856.5 MHz	dB	40	45	-
856.5 ~ 859.5 MHz	dB	15	20	-
878 ~ 883.5 MHz	dB	15	20	-
883.5 ~ 1500 MHz	dB	48	55	-
1500 ~ 2600 MHz	dB	40	45	-
Temperature Coefficient of Frequency	ppm/K	-	-31.0	-
Source Impedance (Single ended)	Ohms	-	50 <sup>(2)</sup>	-
Load Impedance (Single ended)	Ohms	-	50 <sup>(2)</sup>	-
<b>Package type &amp; size</b>				
Length x Width	mm		3.0 x 3.0	
Height	mm		1.3	1.5
<b>Pin Out</b>				
Input	2	Output	5	
Case Ground	1, 3, 4, 6	To be grounded	1, 3, 4, 6	

Note :

- (1) Typical values are nominal performances at room temperature
- (2) No external matching is required

### Measurement circuit

#### 50 Ω / 50 Ω Configuration

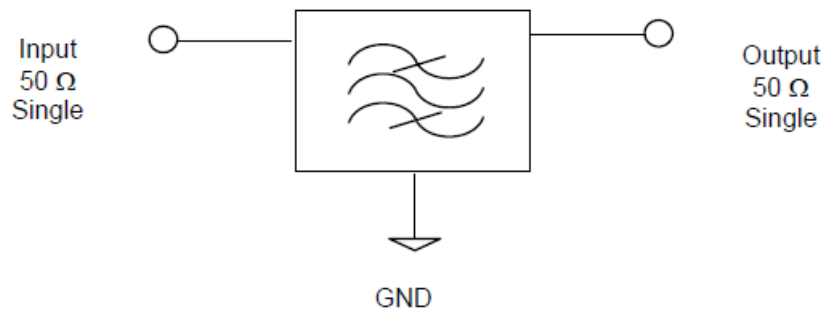

# TMX W331

## Low Loss SAW Bandpass Filter – REMOTE CONTROL

Specification (Rev 5)

January 16<sup>th</sup>, 2013

### Frequency characteristics

#### TYPICAL S21 RESPONSE

##### References

CENTER FREQUENCY = 0 MHz  
 LOSS REFERENCE = 0 dB  
 DELAY REFERENCE = 0  $\mu$ s  
 PHASE REFERENCE = 0 deg

##### Scales

SCALE\_FREQUENCY = 10 MHz/div

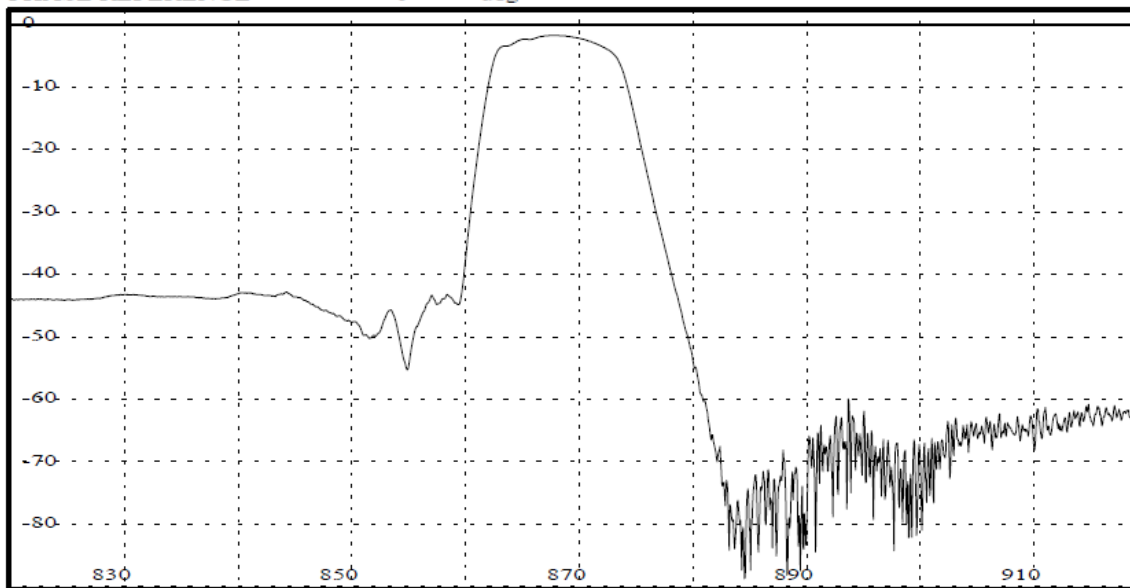

##### References

CENTER FREQUENCY = 0 MHz  
 LOSS REFERENCE = 0 dB  
 DELAY REFERENCE = 0  $\mu$ s  
 PHASE REFERENCE = 0 deg

##### Scales

SCALE\_FREQUENCY = 1 MHz/div

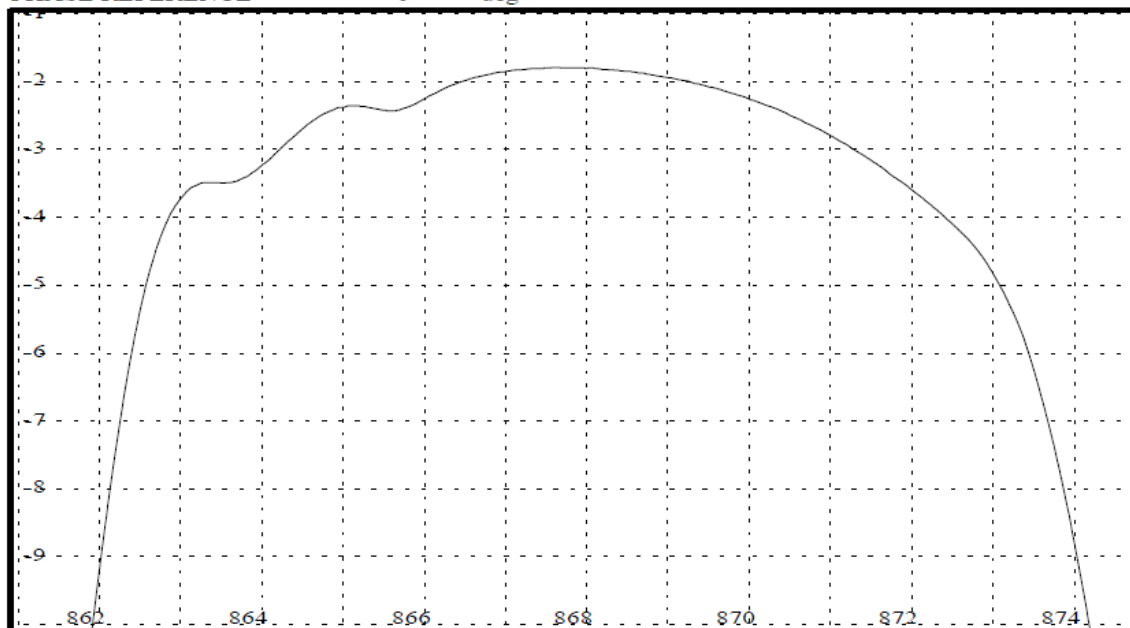

# TMX W331

## Low Loss SAW Bandpass Filter – REMOTE CONTROL

Specification (Rev 5)

January 16<sup>th</sup>, 2013

### Maximum ratings

Storage Temperature Range	°C	[-40°C ; +85°C]
Operating Temperature	°C	[-40°C ; +85°C]
DC Permissive Voltage	V	10V max
Maximum Pulse Input Power	dBm	27
Maximum Input Power Handling (at 50°C during 50 000 hours)	dBm	20

### Recommended reflow soldering profile

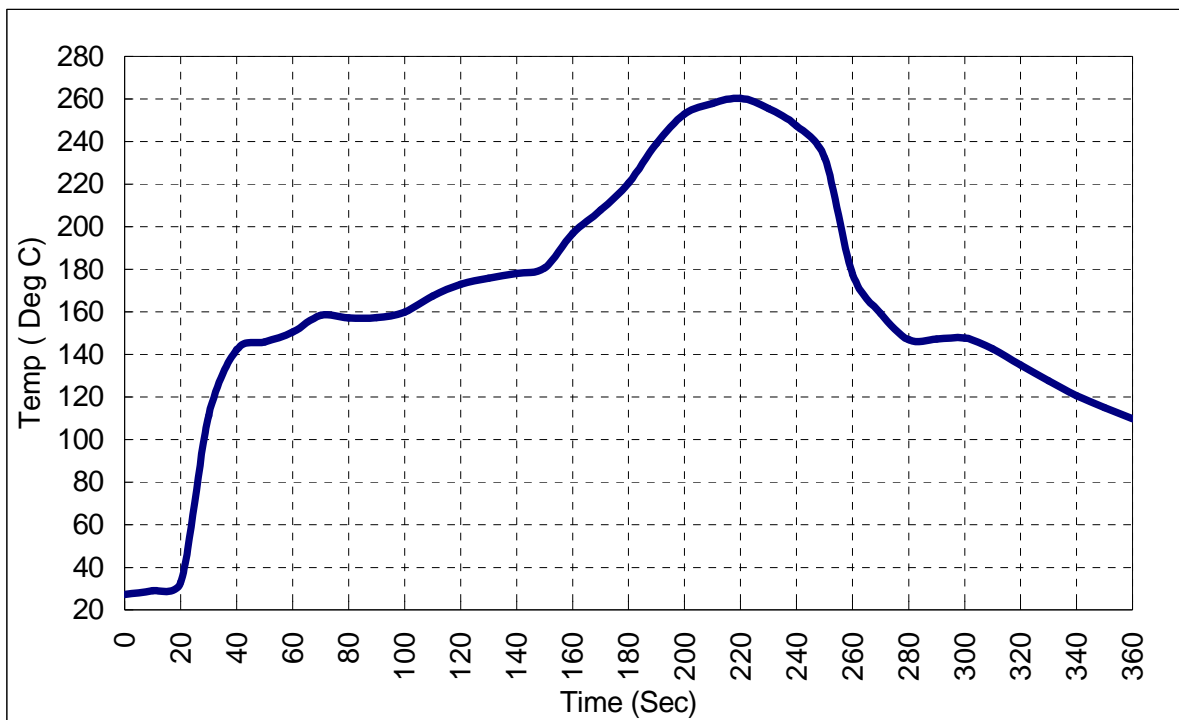

The components shall remain within the electrical specifications after it soldered on the 1mm thickness PCB board and dipped in the solder at  $260 \pm 5$  degC during  $10 \pm 1$  seconds.

The components shall remain within the electrical specifications after it soldered by electric iron, solder at  $350 \pm 10$  degC during 3~4 seconds. Recovery time:  $2h \pm 0.5h$ .

Ultrasonic cleaning may cause deterioration and destruction of the component. Please avoid ultrasonic cleaning.

Only leads of component may be soldered. Please avoid soldering another part of component.

# TMX W331

## Low Loss SAW Bandpass Filter – REMOTE CONTROL

Specification (Rev 5)

January 16<sup>th</sup>, 2013

### Tape Specifications

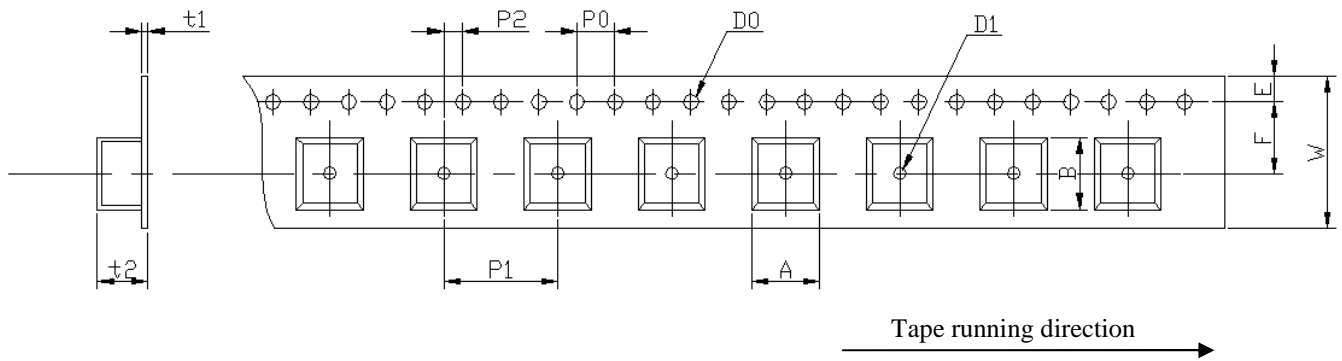

W	F	E	P0	P1	P2	D0	D1	t1	t2	A	B
12 ±0.3	5.5 ±0.3	1.75 ±0.1	4.0 ±0.2	4.0 ±0.1	2.0 ±0.2	∅1.5 ±0.1	∅1.5 ±0.25	0.31 max	1.7 max	3.3 max	3.3 max

unit : mm

### Reel Specifications

TMX W331 is packaged in T&R by 3Kpcs/reel

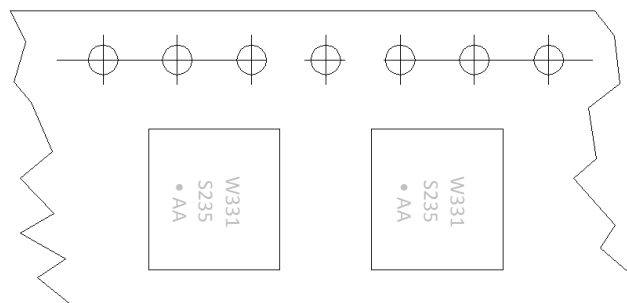
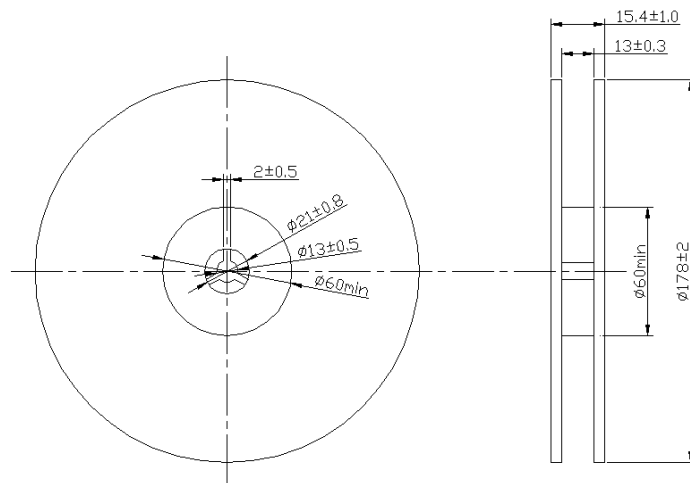

Tape running direction

# TMX W331

## Low Loss SAW Bandpass Filter – REMOTE CONTROL

Specification (Rev 5)

January 16<sup>th</sup>, 2013

### Reliability Tests

1. **Thermal Shock:**

The components shall remain within the electrical specifications after being kept at the condition of heat cycle conditions: TA=-40°C ±3°C, TB=85°C ±2°C, t1=t2=30min, switch time ≤3min & cycle time: 100 times, recovery time: 2h±0.5h.

2. **The Temperature Storage:**

High Temperature Storage: The components shall remain within the electrical specifications after being kept at the 85°C ±2°C for 500 hours, recovery time: 2h ±0.5h.

Low Temperature Storage: The components shall remain within the electrical specifications after being kept at the -40°C ±3°C for 500 hours, recovery time: 2h ±0.5h.

3. **Humidity test:**

The components shall remain within the electrical specifications after being kept at the condition of ambient temperature 60°C ±2°C, and 90~95% RH for 500 hours.

4. **Drop test:**

The components shall remain within the electrical specifications after random free drops 10 times from height of 1.0 meter onto concrete floor, and the specimens shall meet the electrical specifications.

5. **Vibration Fatigue:**

The components shall remain within the electrical specifications after loaded vibration at 10~55Hz, amplitude 1.5mm, X, Y, Z, direction, during 2 hours.

6. **Mechanical Shock:**

The components shall remain within the electrical specifications after 1000 shocks, acceleration 392 m/s<sup>2</sup>, duration 6ms.

**Note: As a result of the particularity of inner structure of SAW products, the components can easily be breakdown by electrostatic shock; so it's mandatory to pay attention to ESD protect during the tests.**