

TMX IT03

RF SAW Filter for Remote Control

Specification (Rev 5)

▣ Features	P01
▣ Package drawing & Pin out	P01
▣ Marking	P01
▣ Technical characteristics	P02
▣ Measurement circuit	P02
▣ Frequency characteristics	P03~04
▣ ESD protection	P05
▣ Maximum ratings	P06
▣ Recommended reflow soldering profile	P06
▣ Tape Specifications	P07
▣ Reel Specifications	P07
▣ Reliability tests.....	P08

TMX IT03

RF SAW Filter for Remote Control

Specification (Rev 5)

January 15th, 2019

Features

- ❑ RF SAW Filter for wireless applications such as Smart metering, Home appliances and Security systems
- ❑ 869 MHz Center Frequency
- ❑ Low Loss (typically 2.9dB) within PassBand Width 868MHz to 870MHz
- ❑ No matching network required for operation at 50Ω
- ❑ Unbalanced to unbalanced operation
- ❑ Ceramic package for Surface Mounted Technology
- ❑ Lead-free and RoHS compliance

Package drawing & Pin out

The product is in conformance with the European RoHs Recast Directive (100/65/EU).

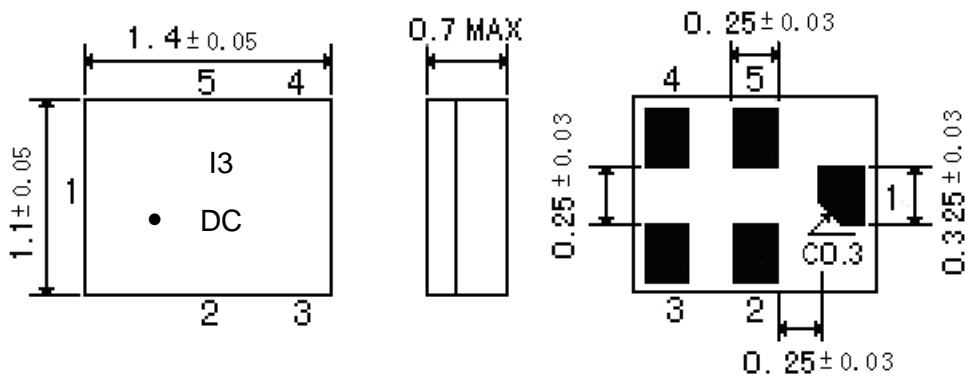

Unit : mm

top view

bottom view

Pin configuration	
1	Input unbalanced
4	Output unbalanced
2, 3, 5	To Be Grounded

Marking		
Line 1	I3	Temexpress designation (TMX IT03)
Line 2	DC	Date Code. See table

Marking is made by Laser

Date Code (1 st digit)	Jan	Feb	Mar	Apr	May	Jun	Jul	Aug	Sept	Oct	Nov	Dec
2016 & 2020	n	p	q	r	s	t	u	v	w	X	y	z
2017 & 2021	A	B	C	D	E	F	G	H	I	K	L	M
2018 & 2022	N	P	Q	R	S	T	U	V	W	X	Y	Z
2019 & 2023	a	b	c	d	e	f	g	h	i	j	k	m

Date Code varies in a 4-year cycle.

Date Code (2 nd digit)	1 st	2 nd	3 rd	4 th	5 th	6 th	7 th	8 th	9 th	10 th
	A	B	C	D	E	F	G	H	J	K
	11 th	12 th	13 th	14 th	15 th	16 th	17 th	18 th	19 th	20 th
	L	M	N	P	Q	R	S	T	U	V
	21 st	22 nd	23 rd	24 th	25 th	26 th	27 th	28 th	29 th	30 th
W	X	Y	Z	a	b	d	e	f	g	h

TMX IT03

RF SAW Filter for Remote Control

Specification (Rev 5)

January 15th, 2019

Technical characteristics

Reference Temperature: +25°C

Electrical Parameters	Unit	Minimum	Typical ⁽¹⁾	Maximum
Center Frequency fo	MHz	-	869.0	-
Maximum Insertion Loss in 868MHz – 870MHz	dB	2.4	2.9	3.2
Amplitude Ripple in 868MHz – 870MHz	dB	-	0.5	1.0
Absolute Attenuation				
0 ~ 791.00 MHz	dB	45	63	-
791.00 ~ 835.00 MHz	dB	45	56	-
835.00 ~ 847.00 MHz	dB	40	53	-
847.00 ~ 862.00 MHz	dB	24	39	-
880.00 ~ 883.00 MHz	dB	30	34	-
883.00 ~ 915.00 MHz	dB	37	47	-
915.00 ~ 1000.0 MHz	dB	50	62	-
1000.0 ~ 3000.0 MHz	dB	30	37	-
3000.0 ~ 4000.0 MHz	dB	24	28	-
4000.0 ~ 5400.0 MHz	dB	20	23	-
5400.0 ~ 6000.0 MHz	dB	18	21	-
VSWR in 868MHz – 870MHz		-	1.5	1.8
Input Impedance	Ohms	-	50 ⁽²⁾	-
Output Impedance	Ohms	-	50 ⁽²⁾	-
Package type & size				
Length x Width	mm		1.4 x 1.1	
Height	mm			0.7
Pin Out				
Input	1	Output	4	
Case Ground		To be grounded	2, 3, 5	

Note :

- (1) Typical values are nominal performances at room temperature
- (2) No external matching is required

Measurement circuit

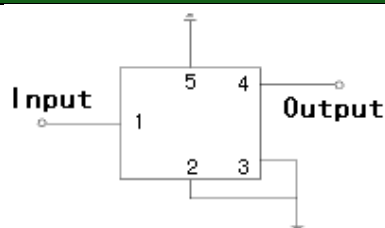

50 Ω / 50 Ω Configuration

TMX IT03

RF SAW Filter for Remote Control

Specification (Rev 5)

January 15th, 2019

Frequency characteristics

TYPICAL S21 RESPONSE

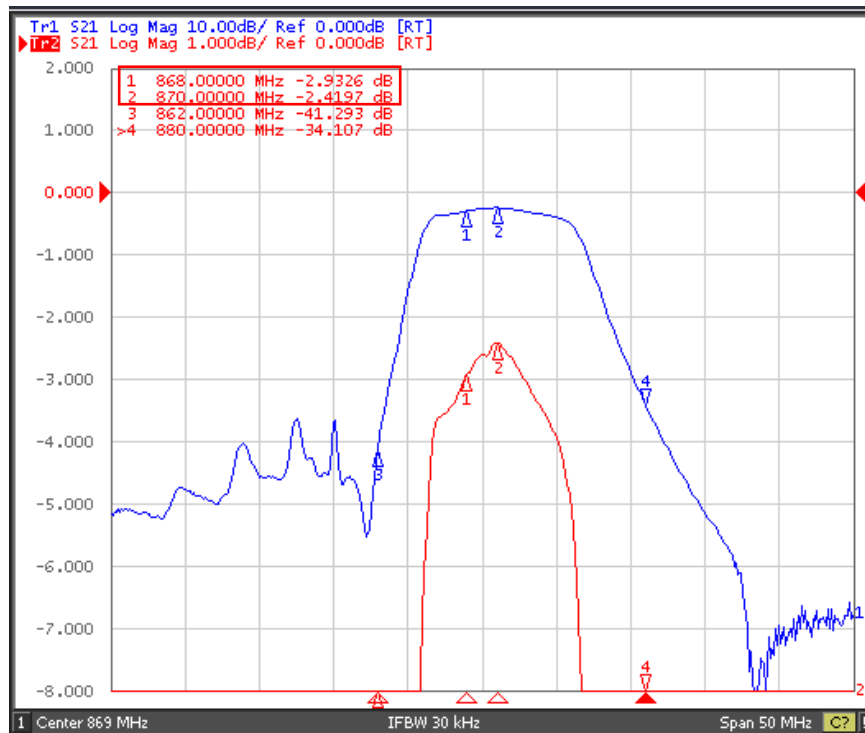

S11 and Group Delay

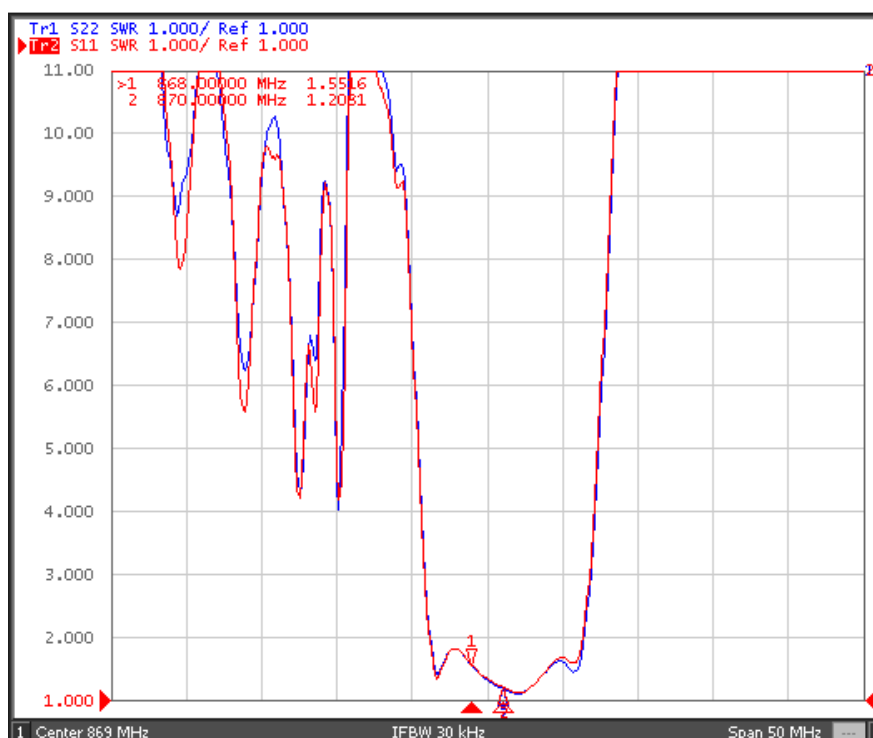

TMX IT03

RF SAW Filter for Remote Control

Specification (Rev 5)

January 15th, 2019

Far Side

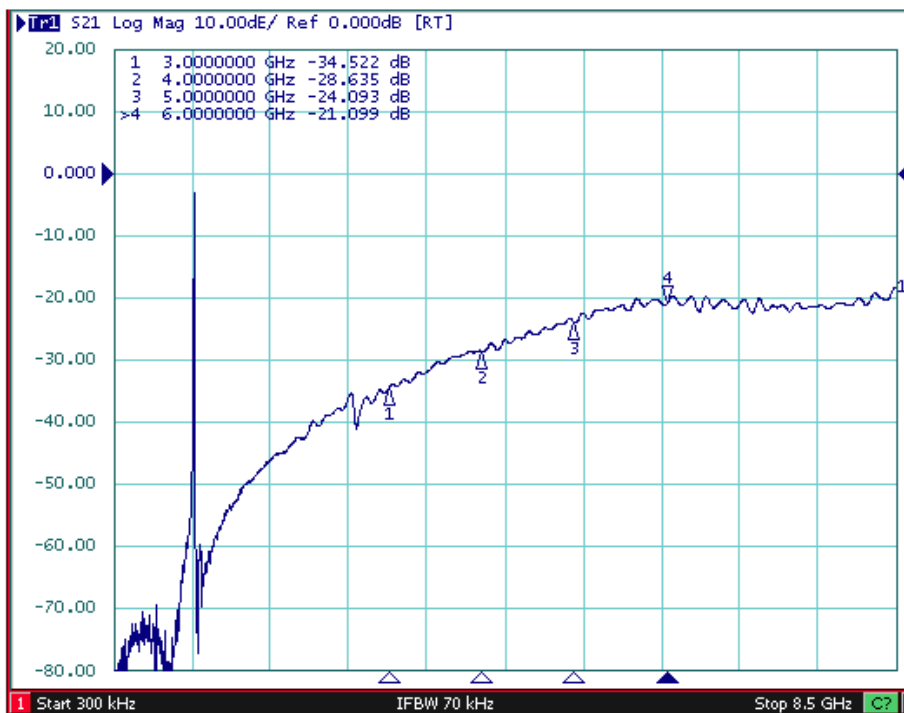
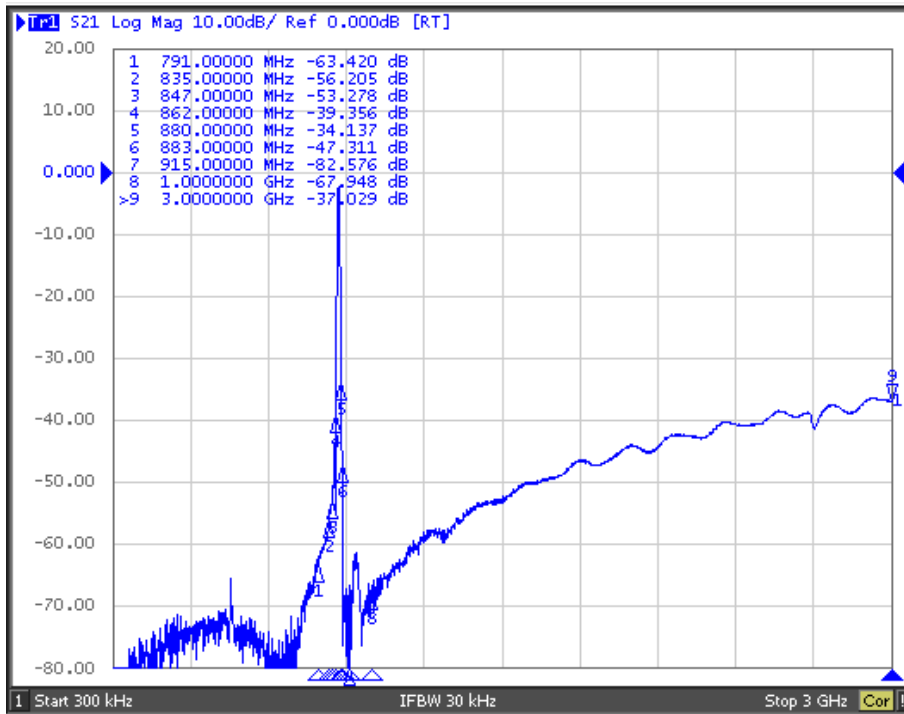

TMX IT03

RF SAW Filter for Remote Control

Specification (Rev 5)

January 15th, 2019

ESD protection

This product is electrostatic sensitive device. When you install or measure it, you should be careful not to add antistatic electricity or high voltage. Please be advised that you had better check anti surge voltage.

To reduce the probability of damages caused by ESD, the following matching topologies should be applied.

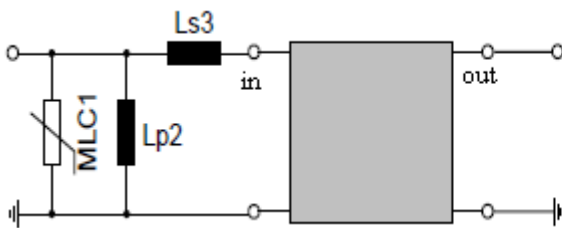

MLC varistor + ESD matching

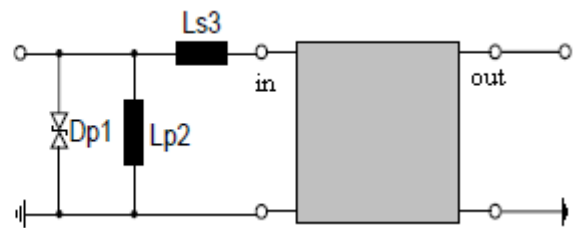

Suppressor diode + ESD matching

ESD matching” should be added to the filter port, where electrostatic discharge is expected. It predominantly appears at the antenna input of RF receivers. Therefore “ESD matching” should be designed to short circuit or block the ESD pulse.

Depending on the input impedance of the SAW filter and the source impedance, the needed component values have to be determined from case to case.

In cases where ESD is minor, the following simplified “ESD matching” topologies can be used :

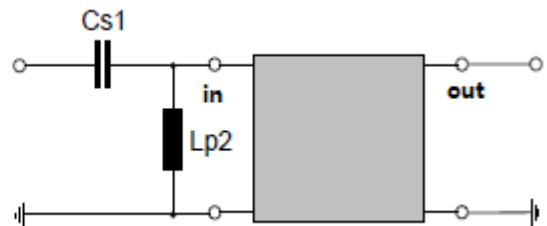
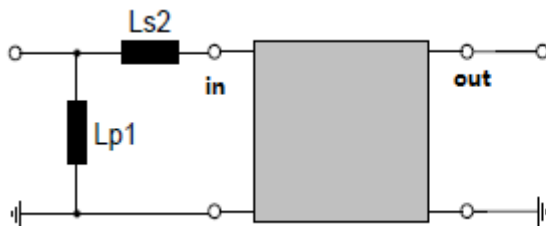

Effectiveness of the applied ESD protection has to be checked according to relevant industry standards or customer specific requirements.

TMX IT03

RF SAW Filter for Remote Control

Specification (Rev 5)

January 15th, 2019

Maximum ratings

Storage Temperature Range	°C	[-40°C ; +85°C]
Operating Temperature	°C	[-40°C ; +85°C]
DC Voltage (between any Terminals)	V	10
Maximum Input Power Handling (at 25°C during 50 000 hours)	dBm	20
Maximum Pulse Input power (4s max with 1 pulse every 30mn max)	dBm	24

Recommended reflow soldering profile

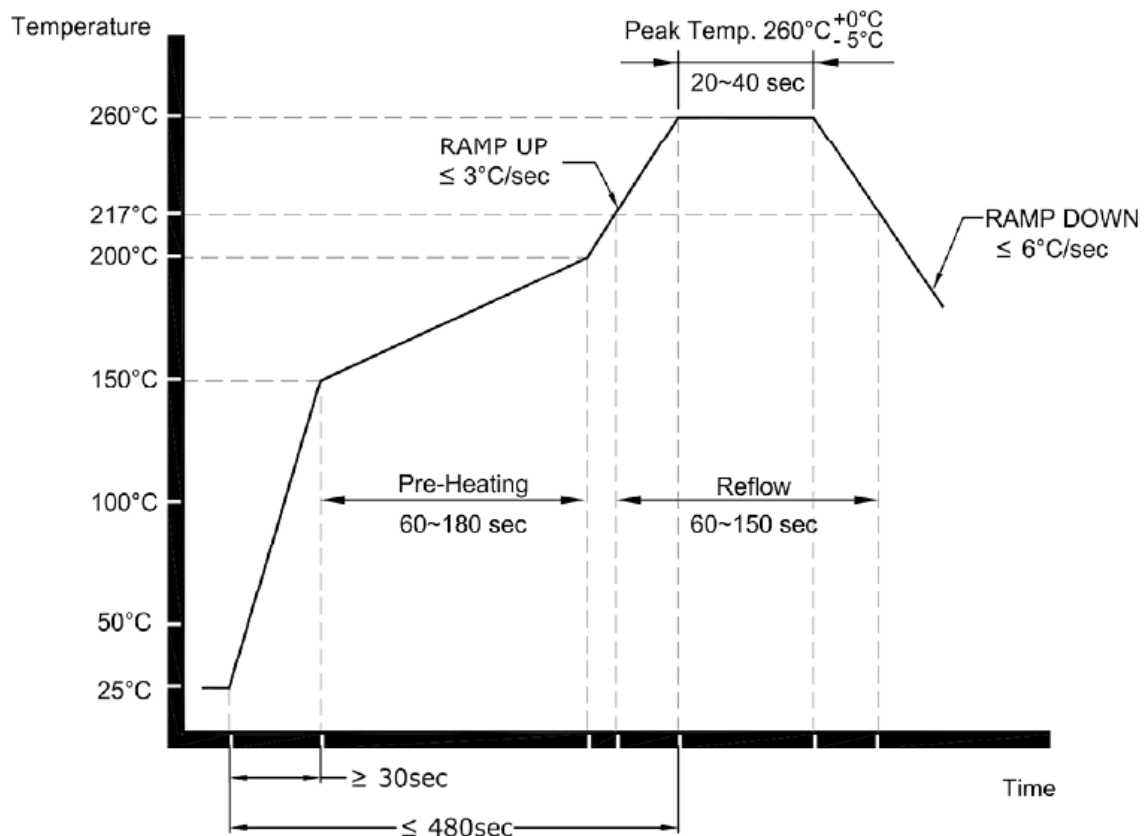

Referred to JEDEC J-STD-020C.

- SAW devices should not be used in any type of fluid such as water, oil, organic solvent, etc.
- Be certain not to apply voltage exceeding the rated voltage of components.
- Be careful of soldering temperature and duration of components when soldering.
- Do not place soldering iron on the body of components.
- Be careful not to subject the terminals or leads of components to excessive force.
- SAW devices are electrostatic sensitive. Please avoid static voltage during operation and storage.
- Ultrasonic cleaning shall be avoided. Ultrasonic vibration may cause destruction of components.

TMX IT03

RF SAW Filter for Remote Control

Specification (Rev 5)

January 15th, 2019

Tape Specifications

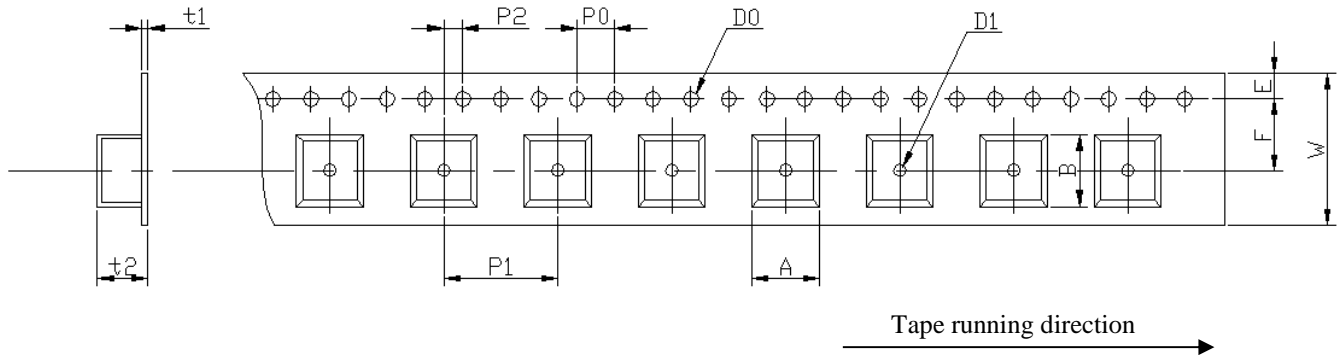

W	F	E	P0	P1	P2	D0	D1	t1	t2	A	B
8.0 ±0.1	3.5 ±0.05	1.75 ±0.1	4.0 ±0.1	4.0 ±0.1	2.0 ±0.05	∅1.5 ±0.1	∅0.5 ±0.1	0.25 max	1.0 max	1.4 max	1.7 max

unit : mm

Reel Specifications

TMX IT03 is packaged in T&R by 4Kpcs/reel

Each reel is inside an anti-static bag.

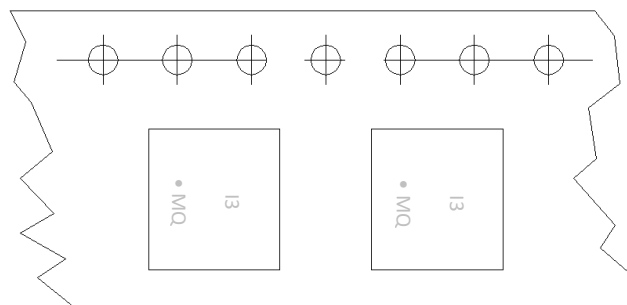
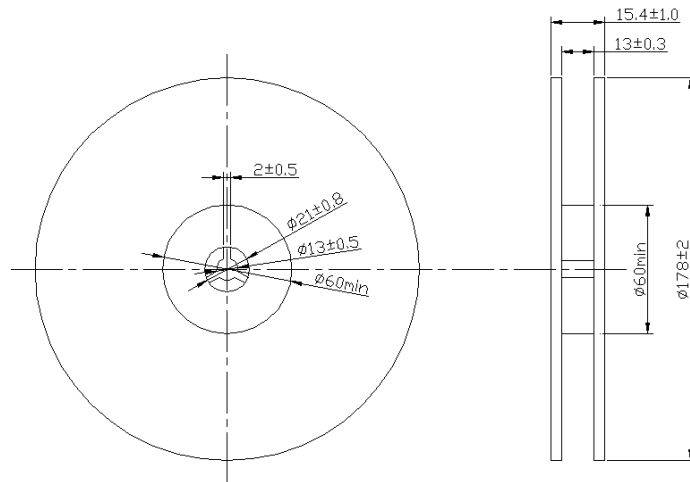

Tape running direction

TMX IT03

RF SAW Filter for Remote Control

Specification (Rev 5)

January 15th, 2019

Reliability Tests

	Test item	Condition of test
1	Mechanical shock	(a) Drops: 3 times on concrete floor (b) Height: 1.0 m
2	Vibration resistance	(a) Frequency of vibration: 10~55Hz (b) Amplitude: 1.5 mm (c) Directions: X,Y and Z (d) Duration: 2 hours
3	Moisture resistance	(a) Condition: 40°C±2°C, 93+2 -3% RH. (b) Duration: 96 hours (c) Wait 4 hours before measurement
4	Climatic sequence	(a) +70°C for 16 hours (b) +55°C for 24 hours, 90~95% RH (c) -25°C for 2 hours (d) +40°C for 24 hours, 90~95% RH (e) Wait 4 hours before measurement
5	High temperature exposure	(a) Temperature: 85°C (b) Duration: 250 hours (c) Wait 4 hours before measurement
6	Temperature cycling	(a) +85°C for 30 minutes ⇒ -40°C for 30 minutes repeated 120 times (b) Wait 4 hours before measurement

Note: As a result of the particularity of inner structure of SAW products, the components can easily be breakdown by electrostatic shock; so it's mandatory to pay attention to ESD protect during the tests.