



QESM08

SMD 2.5x2.0 Crystal – Ceramic SMD packaged
Specification (Rev-B)

▣ Electrical Characteristics	P01
▣ ESR vs. frequency range and Mode of vibration	P01
▣ Mechanical Characteristics	P01
▣ Ordering Information	P02
▣ Suggested Reflow Soldering profile	P02
▣ Tape Drawing	P03
▣ Reel Drawing	P03

QESM08

SMD 2.5x2.0 Crystal – Ceramic SMD packaged
Specification (rev-B)

Aug 26th, 2013

Electrical Characteristics

Electrical Parameters	Unit	Minimum	Typical	Maximum	Test conditions
Frequency range	MHz	12		54	
Frequency Tolerance (at 25°C)	± ppm	10	15	30	Refer to Ordering Information
Temperature Stability	± ppm	10	15	30	Refer to Ordering Information
Operating Temperature Range	°C		-20/+70	-40/+85	Refer to Ordering Information
Storage temperature range	°C	-55		+125	
Shunt capacitance C ₀	pF			3.0	
Load capacitance	pF	8pF ~ 16pF			Refer to Ordering Information
Drive level	µW		50	100	
Aging (First Year)	± ppm			2	Ref at 25°C
Insulator resistance	MΩ	500			At 100V _{DC}

Customized specification upon request

ESR vs. frequency range and Mode of vibration

Frequency range (MHz)	Mode of vibration	Max ESR (Ω)
12.000 to 15.999	Fundamental (AT-cut)	120
16.000 to 19.999	Fundamental (AT-cut)	100
20.000 to 29.999	Fundamental (AT-cut)	80
30.000 to 54.000	Fundamental (AT-cut)	50

Mechanical Characteristics

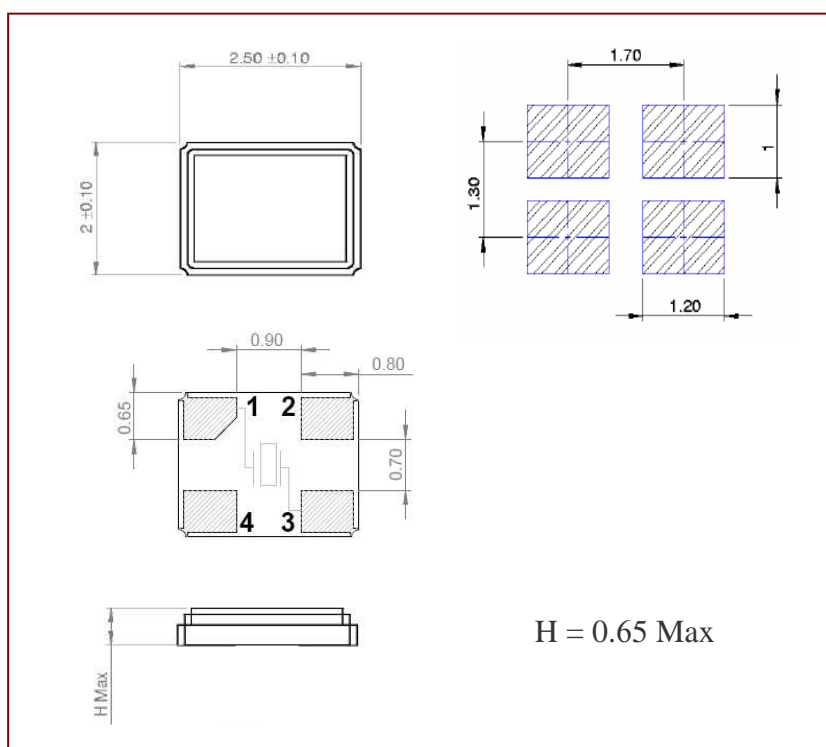

Marking for QESM08

Line 1	Rakon code (6 digits)
Line 2	T+date code (YWW)

Mechanical conditions

Vibration	10g, 10Hz to 2KHz according to standard CEI 68-2-63
Shocks	100g, 6ms according to standard CEI 68-2-27

Note 1 : Pin 2 and Pin 4 are connected through cover. In case connected to GND, frequency might be drifted.

Note 2 : QESM08 is fully RoHS compliant.

QESM08

SMD 2.5x2.0 Crystal – Ceramic SMD
packaged *Specification (rev-B)*

Aug 26th, 2013

▣ Ordering Information

Part numbering system						
QESM08	1	10	HQ	10	10	26.0000MHZ
Package type	Vibration mode	Frequency tolerance	Operating temperature range	Frequency stability	Load Capacitance	Nominal Frequency (MHz)
SMD Package QESM08 : SMD ceramic 2.5 x 2.0	1=Fundamental	10=±10ppm 20=±20ppm 30=±30ppm 50=±50ppm	D=-40°C F= -30°C H=-20°C J=-10°C L=0°C M=+50°C N=+55°C O=+60°C Q=+70°C T=+85°C	10=±10ppm 20=±20ppm 30=±30ppm 50=±50ppm	10=10pF Please, enter the value of load capacitance	Please enter the nominal frequency

▣ Suggested Reflow Soldering Profile

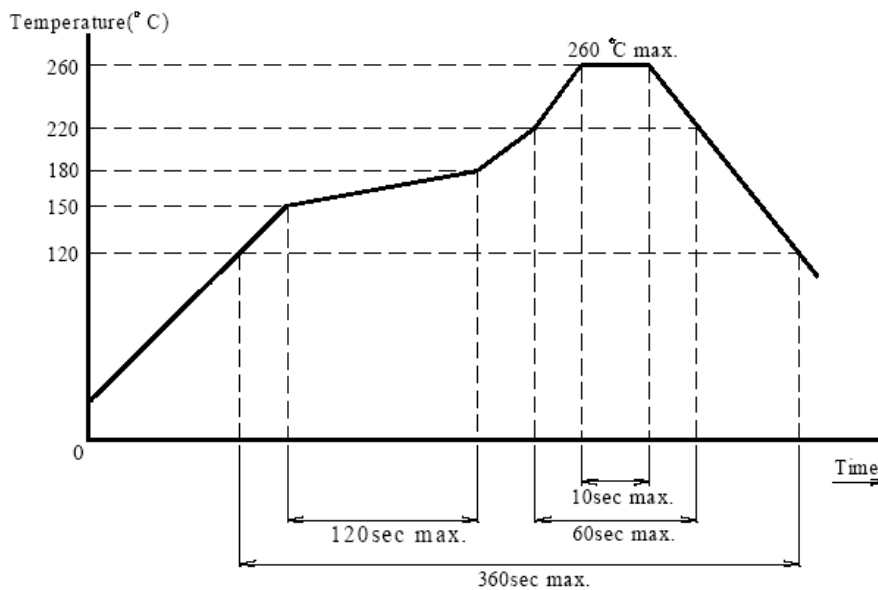

QESM08

SMD 2.5x2.0 Crystal – Ceramic SMD packaged *Specification (rev-B)*

Aug 26th, 2013

▣ Tape Drawing

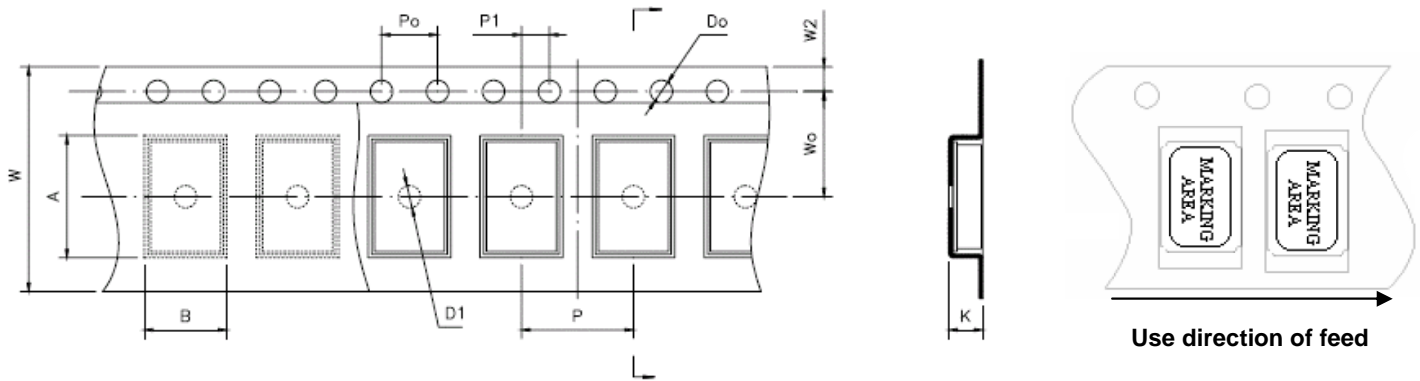

	Code	Dimension	Tolerance
Pitch of components	P	4.0	± 0.1
Pitch of sprocket hole	Po	4.0	± 0.1
Length from hole center to component center	P1	2.0	± 0.1
Width of carrier tape	W	8.0	± 0.3
Width of adhesive tape	W0	3.5	± 0.1
Height of component hole	A	2.8	± 0.1
Width of component hole	B	2.3	± 0.1
Gap of hold down tape and carrier tape	W2	0.5	± 0.1
Diameter of sprocket hole	Do	∅ 1.5	± 0.05
Diameter of feed hole	D1	∅ 1.5	± 0.25
Total of tape thickness	K	1.0	± 0.1

▣ Reel Drawing

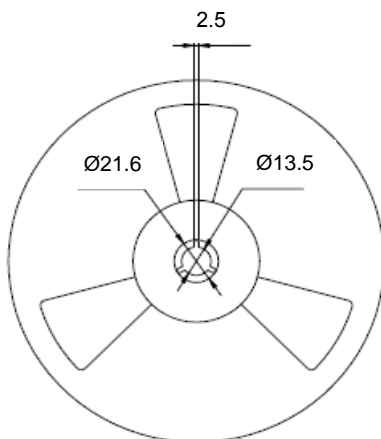

Multiple :
3000pcs per reel

