



QEN4

DIL 8 Pin Half Size XO – Communications Equipment Application
Specification (Rev-C)

▣ Electrical Characteristics	P01
▣ Mechanical Characteristics	P02
▣ Ordering Information	P02

QEN4

DIL 8 Pin Half Size XO – Communications Equipment Application

Specification (rev-C)

December 20th, 2013

Electrical Characteristics

Electrical Parameters	Unit	Minimum	Typical	Maximum	Test conditions
Frequency range	MHz	0.5		150	
Output logic	HCMOS / TTL Output				
Operating temperature range (see table 1)	°C		0 to +70	-40 to +85	Refer to Ordering Information
Storage temperature range	°C	-55		+125	
Power supply voltage (Vcc)	V	+3.3 (± 5%)		+5.0 (± 5%)	Refer to Ordering Information
Frequency Stability (see note 1)	± ppm	15	50	100	Refer to Ordering Information
Aging (First Year)	± ppm			5	Ref at 25°C
Input current (see table 1)	mA				
Output load (see table 2)	HCMOS load	pF	15		
	TTL load	LS-TTL	5		
Duty cycle	%		40/60		Refer to Ordering Information
Rise & Fall time	ns			10	From 10% Vcc to 90% Vcc
Start-up time	ms			10	

Note 1: Include 25°C tolerance, operating temperature range, input voltage change, load change, first year aging, shock and vibration.

Frequency range (MHz)	Vcc=5V	Vcc=3.3V
	Cl=15 pF	Cl=15pF
0.500 to 23.999	20 mA	15 mA
24.00 to 49.999	30 mA	20 mA
50.00 to 69.999	40 mA	30 mA
70.00 to 150.00	60 mA	45 mA

Frequency range (MHz)	Vcc=5V	Vcc=3.3V
	Up to 50.000	50pF
Up to 70.000	30pF	20pF
Up to 150.00	15pF	15pF

Operating Temperature Range	±15ppm	±25ppm	±50ppm	±100ppm
0 to 70°C	Yes	Yes	Yes	Yes
-10 to 70°C	-	Yes	Yes	Yes
-20 to 70°C	-	Yes	Yes	Yes
-40 to 85°C	-	Yes	Yes	Yes

QEN4

DIL 8 Pin Half Size XO – Communications Equipment Application

Specification (rev-C)

December 20th, 2013

▣ Mechanical Characteristics

BOTTOM VIEW

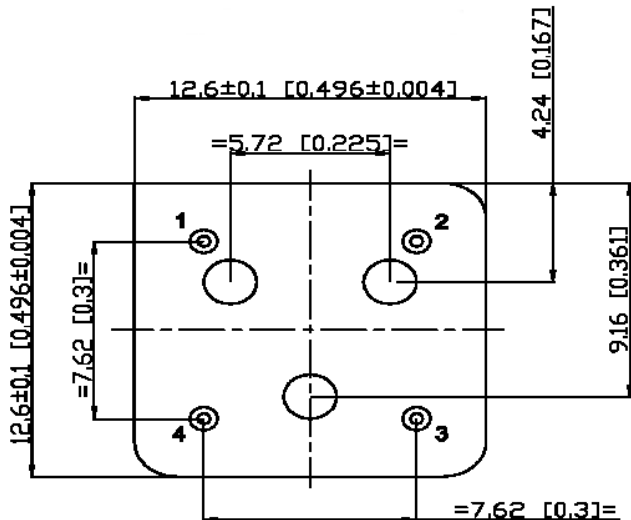

Pin connections	
#1	N.C. or Tri state
#2	Ground
#3	Output
#4	+Vcc

Tri state function	
Pin #1	Output (Pin #3)
Open	Active
"1"	Active
"0"	High Z

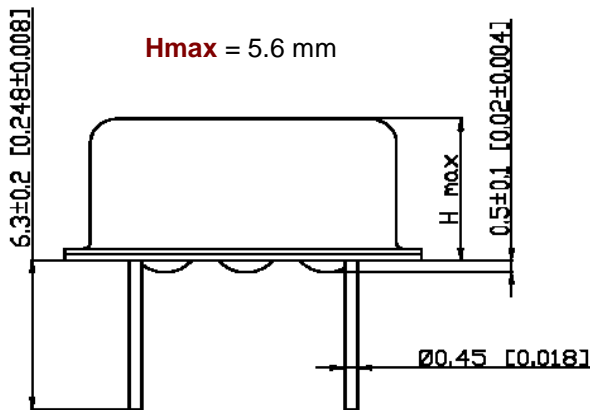

Marking	
Line 1	Temexpress part number
Line 2	Frequency in MHz (6 digits)
Line 3	Date code (YYWW) – Manufacturing code

Example for QEN4H DT50 / 49.152MHz

- ⇒ Line 1 : QEN4H DT50
- ⇒ Line 2 : 49.152MHz
- ⇒ Line 3 : 1347-I

Packaging : Antistatic Tube (40pcs/tube)

▣ Ordering Information

Part numbering system					
QEN4	H	J	LQ	25	10.000MHZ
Package type	Supply Voltage	Option	Operating temperature range	Frequency stability	Nominal Frequency (MHz)
DIL Package QEN4 : 8 Pin Half Size	H : +5.0V BH : +3.3V	J : Tri-state output R : Duty cycle 45/55%	LQ : 0 to +70°C JQ : -10 to +70°C HQ : -20 to +70°C DT : -40 to +85°C	15 : ±15ppm 25 : ±25ppm 50 : ±50ppm 100 : ±100ppm	Please enter the nominal frequency