



QEA101 / QEA101V

SMD 7x5 TCXO / VC-TCXO – Communications Equipment Application
Specification (Rev-C)

▣ Electrical Characteristics	P01
▣ Environmental Specifications	P01
▣ Mechanical Characteristics	P02
▣ Ordering Information	P03
▣ Test Circuit	P03
▣ Packaging Drawing	P04
▣ Suggested Reflow Soldering	P05

QEA101 / QEA101V

SMD 7x5 TCXO / VC-TCXO – Communications equipment Application

Specification (rev-C)

October 17th, 2005

Electrical Characteristics

- Output : Clipped SineWave
- Load : 10kΩ//10pF

Electrical Parameters	Unit	Minimum	Typical	Maximum	Test conditions
Frequency Range	MHz	10		26	
Operating Temperature Range	°C	0 to 55		-40 to 85	Refer to Ordering Information
Storage Temperature Range	°C	-55		85	
Power supply	V	2.8		5.0	Refer to Ordering Information
Frequency Stability Preset frequency (25°C) Vs Temperature Range Vs Voltage variation (± 5%) Vs Load variation (± 10%)	ppm		2.5	1.0 0.2 0.2	Refer to Ordering Information
Aging	ppm			1.0	First year at 25°C
Supply Current 10MHz ≤ Fo ≤ 15.000MHz 15MHz ≤ Fo ≤ 20.000MHz 20MHz ≤ Fo ≤ 26.000MH	mA			1.5 2.0 2.2	With load 10kΩ//10pF
Start-Up Time	ms		2		
Output Voltage	Vp-p	0.8			Clipped sine wave
Pulling Range	Ppm/V	5		15	Vcont = 1.5 ± 1.0V
Phase Noise offset 10Hz offset 100Hz offset 1KHz offset 10KHz	dBc/Hz		-90 -110 -125 -130		Typical value for 12.8MHz TCXO.

Environmental Specifications

Electrical Parameters	Unit	Minimum	Typical	Maximum
Vibration Test	Freq. : 10~ 2 000Hz, 20G Cycle : 1.25mm, 3 directions each 4 hours Norm : MIL-STD-883D 2005.2 Condition A.			
Shock Test	Conditions : 1 500g, Half Sine, 0.5ms Times : 3 times in 3 directions Norm : : MIL-STD-883D 2002.3 Condition B.			

QEA101 / QEA101V

SMD 7x5 TCXO / VC-TCXO – Communications equipment Application
 Specification (rev-C)

October 17th, 2005

▣ Mechanical Characteristics

BOTTOM VIEW

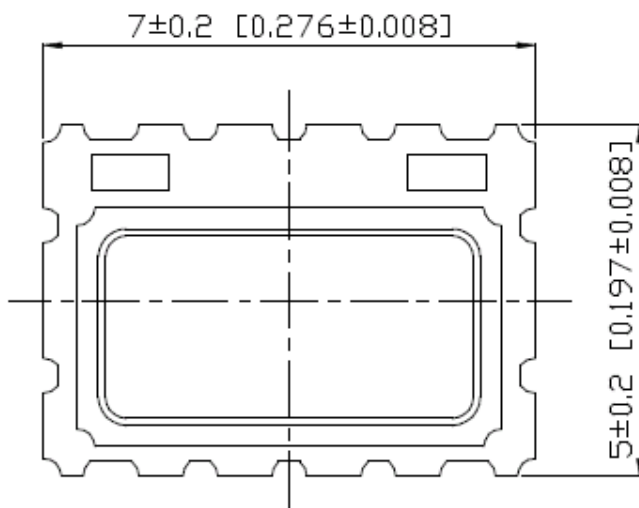
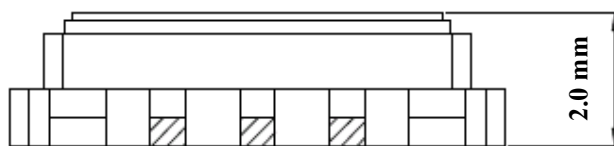
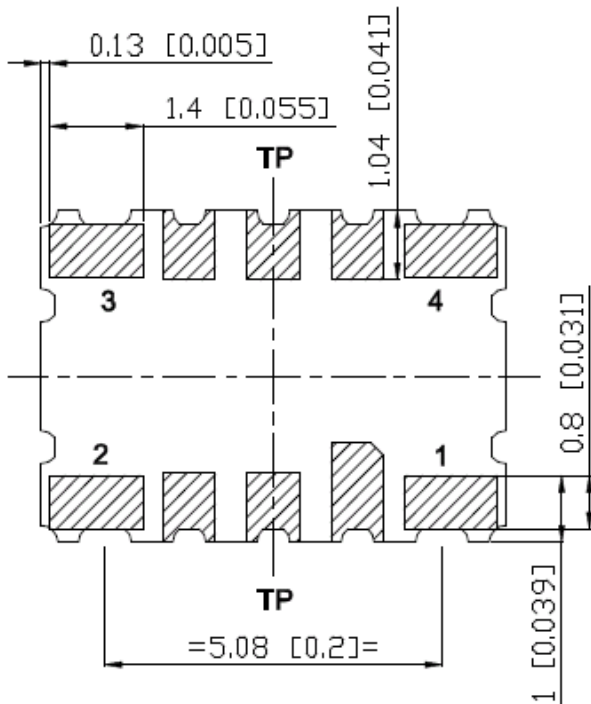

SUGGESTED PAD

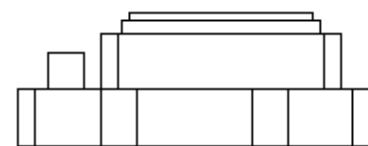
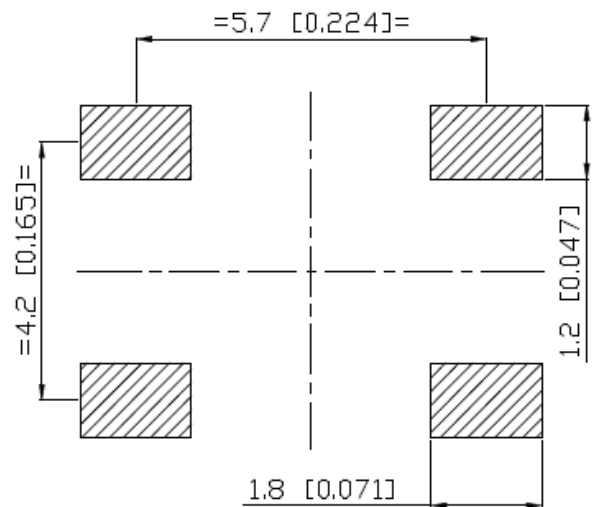

Pin connections	
#1	Vcont or NC
#2	Ground
#3	Output
#4	+Vcc

Marking	
Line 1	E3 (TCXO) or G3 (VCTCXO) + stability letter + voltage letter + Output letter
Line 2	Frequency in MHz (6 digits) + manuf code

Exemple for QEA101V AE0 / 13MHz

- ⇒ Line 1 : G3AEO
- ⇒ Line 2 : 13.00-N

QEA101 / QEA101V

SMD 7x5 TCXO / VC-TCXO – Communications equipment Application

Specification (rev-C)

October 17th, 2005

Ordering Information

Part numbering system					
QEA101	V	A	E	O	12.800MHZ
↓	↓	↓	↓	↓	↓
Package type	Voltage Control	Temperature Stability	Supply voltage	Output	Nominal Frequency (MHz)
SMD Package QEA101 : SMD 7x5	Blank : TCXO V : VC-TCXO	A : ± 2.5ppm vs -30 to +75°C B : ± 1.5ppm vs -20 to +70°C C : ± 1.0ppm vs 0 to +55°C D : ± 3.5ppm vs -40 to +85°C	A : + 5.0V D : +3.3V E : +3.0V L : +2.8V	0 : Clipped sinewave	Please enter the nominal frequency

Test Circuit

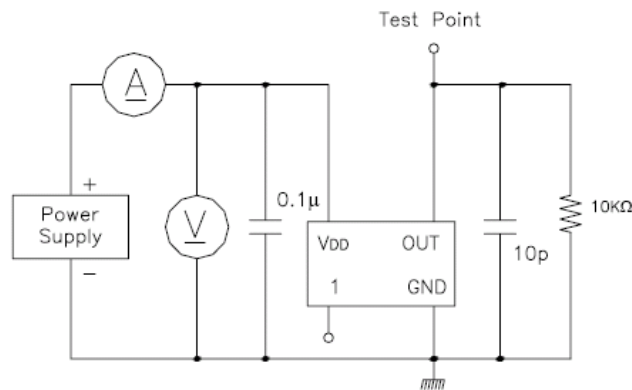

Tape Drawing

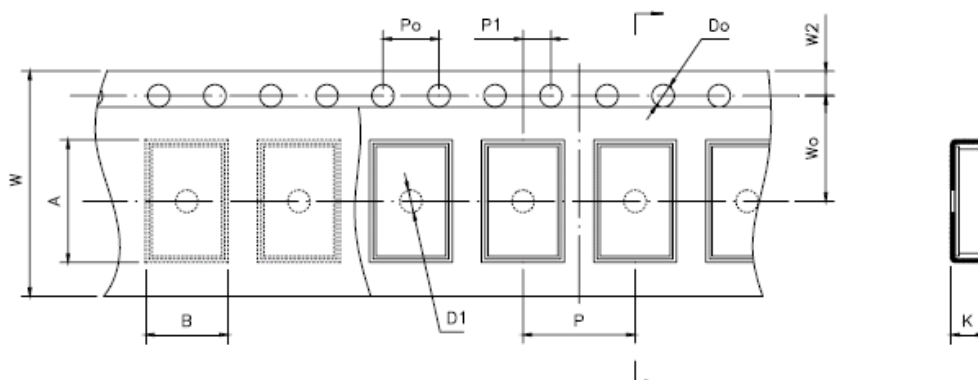

QEA101 / QEA101V

SMD 7x5 TCXO / VC-TCXO – Communications equipment Application
 Specification (rev-C)

October 17th, 2005

	Code	Dimension	Tolerance
Pitch of components	P	8.0	± 0.1
Pitch of sprocket hole	Po	4.0	± 0.1
Length from hole center to component center	P1	2.0	± 0.1
Width of carrier tape	W	16.0	+0.3/-0.1
Width of adhesive tape	W0	7.5	± 0.1
Height of component hole	A	8.18	± 0.1
Width of component hole	B	5.56	± 0.1
Gap of hold down tape and carrier tape	W2	1.75	± 0.1
Diameter of sprocket hole	Do	∅ 1.5	± 0.05
Diameter of feed hole	D1	∅ 1.5	± 0.25
Total of tape thickness	K	2.16	± 0.1

Reel Drawing

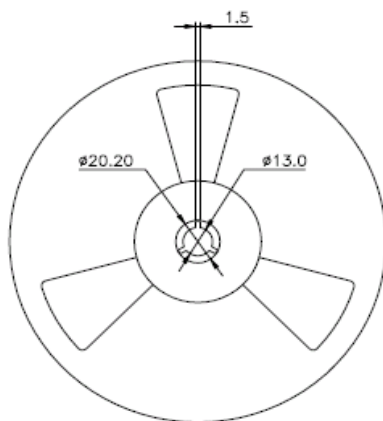

Multiple : 1Kpcs per Reel

Unit : mm

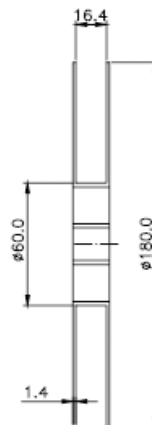

QEA101 / QEA101V

SMD 7x5 TCXO / VC-TCXO – Communications equipment Application
 Specification (rev-C)

October 17th, 2005

▣ Suggested Reflow Soldering Profile

